



Riera Nadeu 

RINA JET\_Flash Dryers®

FOUNDED IN  
**1952**





Innovation from  
Barcelona

More than  
2000 projects Worldwide

Quality equipment  
Since 1952

Taylor made  
projects

Low maintenance  
machines

Energy efficient  
solutions



S

Since 1982



**Innovations**

\_Exclusive technology.

**Benefits**

- \_Modular structure.
- \_Compact design.
- \_High efficiency.

**Clients**



**DSM**



**COLOROBBLIA**



**Ercros**



**JM Johnson Matthey**  
Inspiring science, enhancing life

**esmalglass·itaca**  
grupo



**riera**  
www.riera

S

Installation diagram



- 1 \_ Head fan
- 2 \_ Heating chamber
- 3 \_ **Rina-Jet Turbo Dryer**
- 4 \_ Wet solid inlet
- 5 \_ Sleeves filter
- 6 \_ Cyclone
- 7 \_ Tail fan
- 8 \_ Dry solid discharge system
- 9 \_ Wet solid hopper
- 10 \_ Feeding screw conveyor
- 11 \_ Agitated feeding hopper

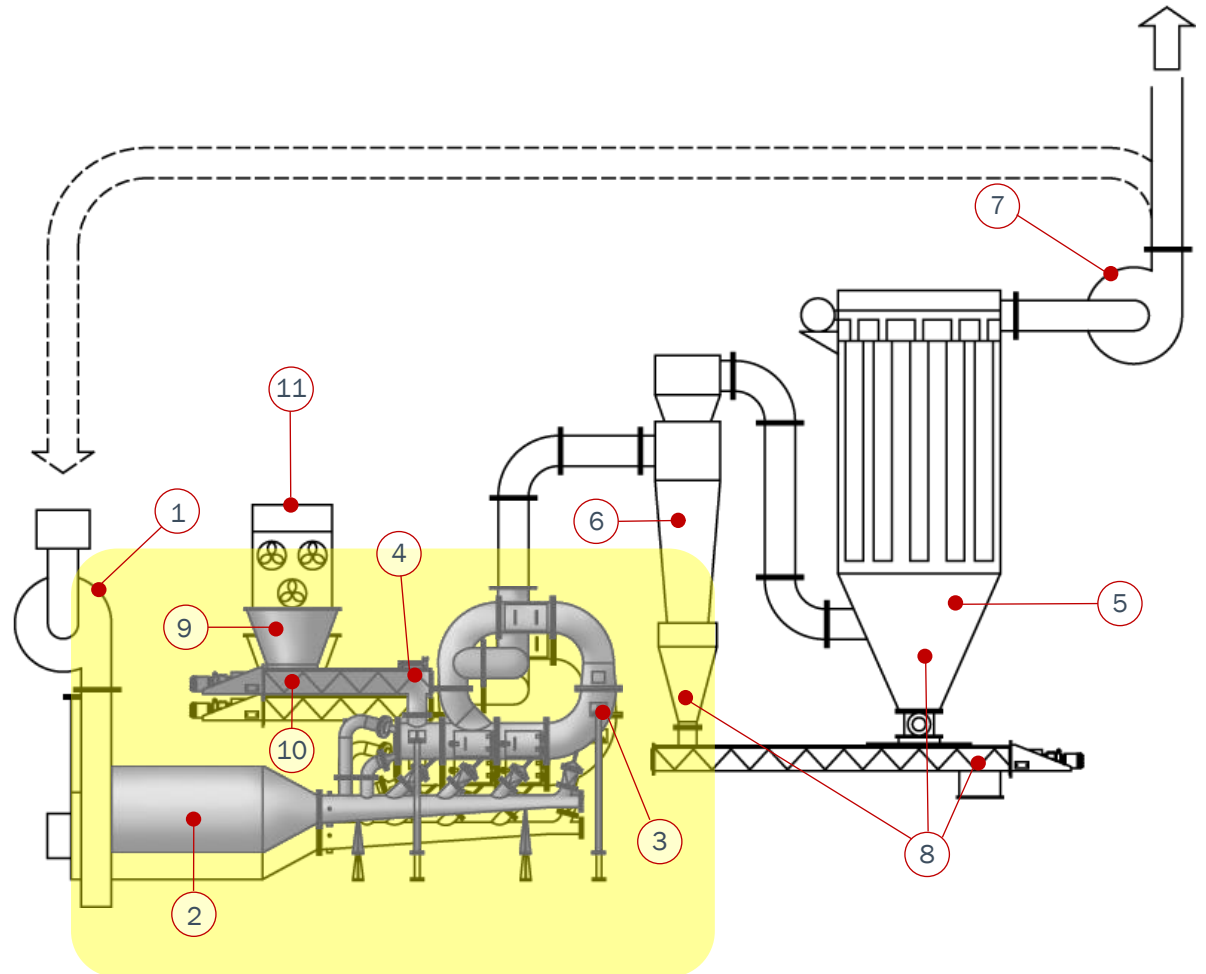



- 1 \_ Hot air
- 2 \_ Hot air distributor
- 3 \_ Feeding (solutions & susp.)
- 4 \_ Feeding (wet solids)
- 5 \_ Drying chamber
- 6 \_ **Rina-Jet Turbo Dryer**
- 7 \_ Recycling
- 8 \_ Exhaust / dry product exit
- 9 \_ Inspection door
- 10 \_ Inspection gate

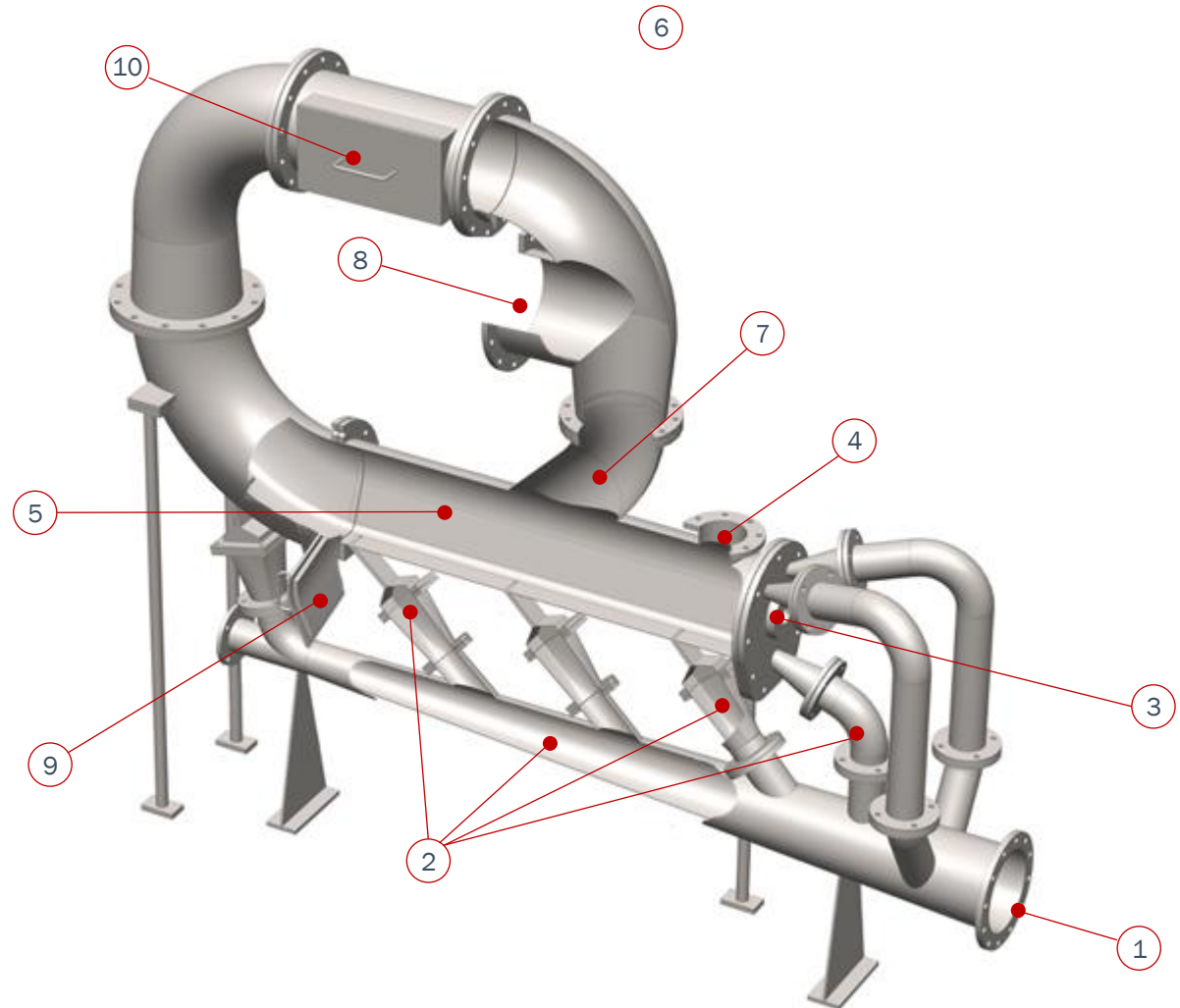

S

Jet diagram



- 1 \_ Hot air
- 2 \_ Hot air distributor
- 3 \_ Feeding (solutions & susp.)
- 4 \_ Feeding (wet solids)
- 5 \_ Drying chamber
- 6 \_ **Rina-Jet Turbo Dryer**
- 7 \_ Recycling
- 8 \_ Exhaust / dry product exit
- 9 \_ Inspection door
- 10 \_ Inspection gate

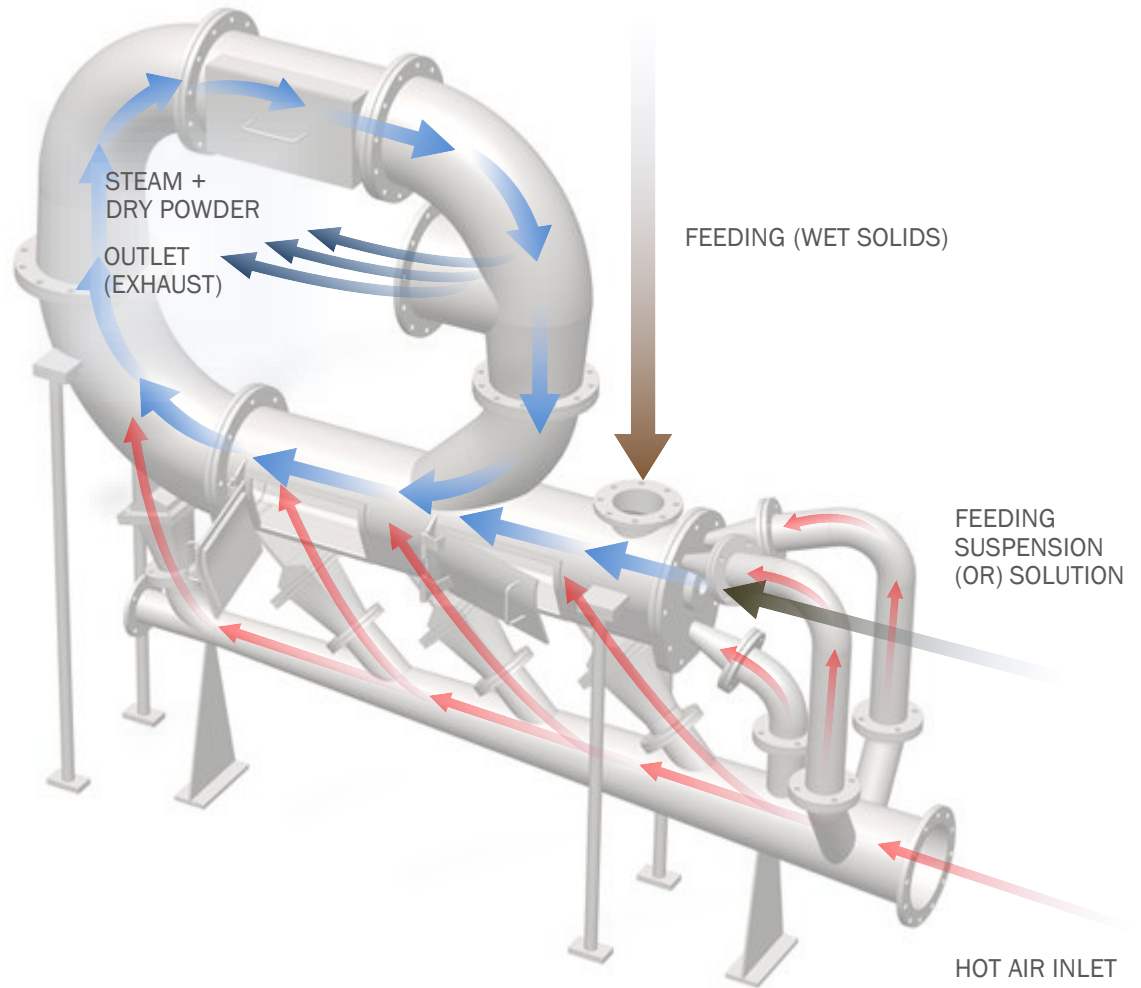

S

Installation S-Lab





## Applications

- \_ Base chemical.
- \_ Minerals.
- \_ Enamels.
- \_ Pigments / Dyestuffs.
- \_ Starch.
- \_ Calcium carbonate.
- \_ Biomass.
- \_ Pharmaceutical & chemical products.
- \_ Gypsum.
- \_ Waste products.





**S**

Product range



MODELS	Throughput (wet product)		Evaporation water		Dry product		Throughput (wet product)		Evaporation water		Dry product	
	Kg/h	Up to	Kg/h	Up to	Kg/h	Up to	Lb (US)	Up to	Lb (US)	Up to	Kg/h	Up to
S-LAB	2	10	1	4	0,5	6	4,5	22	2,20	9	1,10	13
S-605	25	125	15	75	10	100	55	275	33	165	22	220
S-806	100	200	50	105	75	225	220	440	110	230	165	495
S-1008	200	400	125	250	175	225	440	880	275	550	385	550
S-1210	350	600	200	350	300	500	770	1300	440	770	660	1100
S-1412	500	1000	300	500	450	900	1100	2200	660	1100	990	2000
S-1816	750	1500	400	1000	600	1250	1650	3300	880	2200	1320	2750
S-2018	1200	3000	750	1750	1000	2750	2650	6600	1650	3850	2200	6000
S-2220	2500	5000	1000	2200	1500	3250	5500	11000	2200	4850	3300	7000
S-2422	2500	6500	1250	2500	1750	5000	5500	14300	2750	5500	3850	11000
S-2824	2500	8000	1500	3000	2500	6000	5500	17600	3300	6600	5500	13200
S-3632	5000	12500	1500	3000	2750	10000	11000	27500	3300	7700	6000	22000

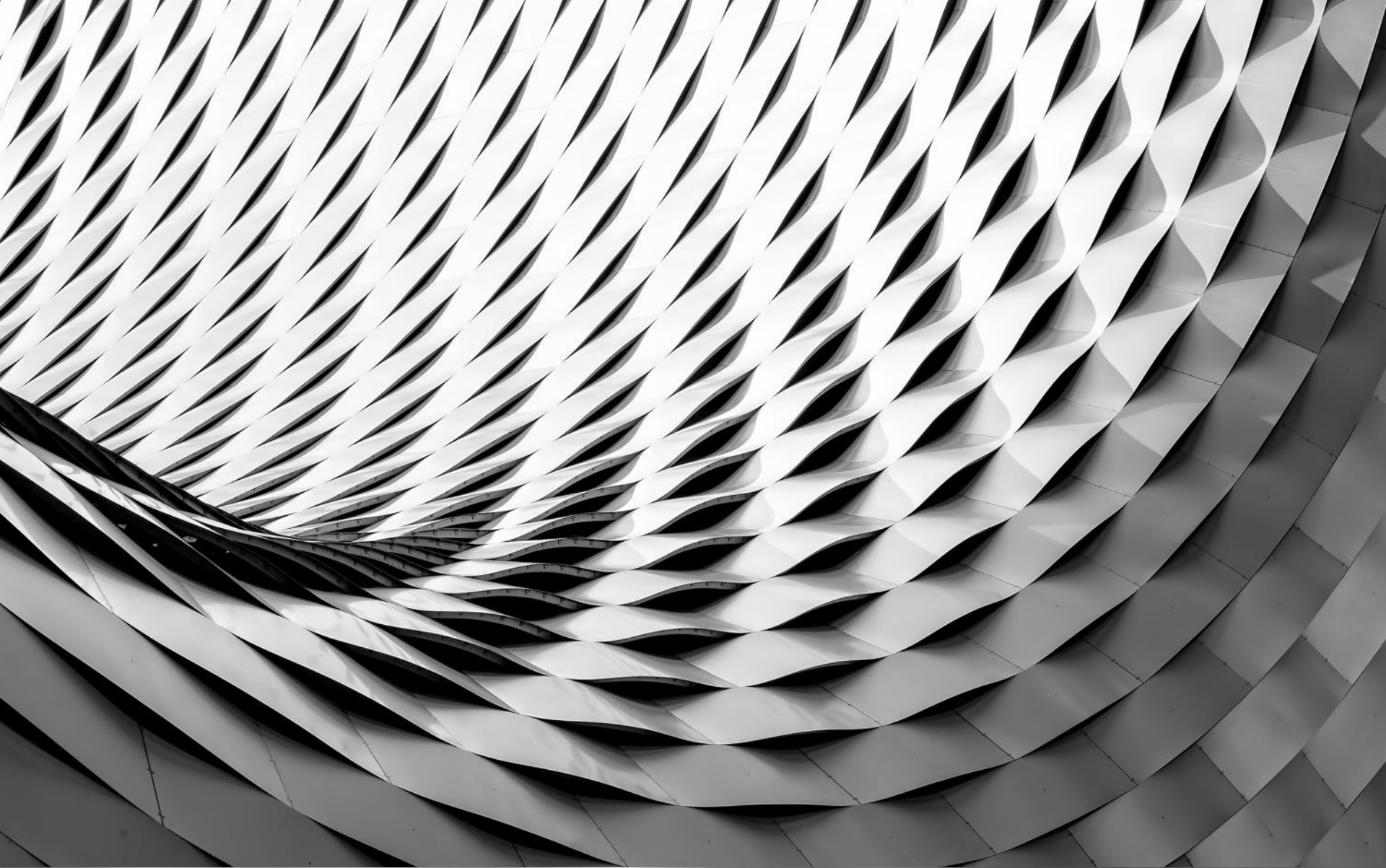

Riera Nadeu 

C. Cal Ros dels Ocells, 1-3. Pol Ind. Coll de la Manyà, 08403. Barcelona.  
T\_938 40 70 72 F\_938 40 70 85 W\_rieranadeu.com

